

SCPHA

Dec 8, 2024

39 SCPHA Green Horse
40 SCPHA Green Rider

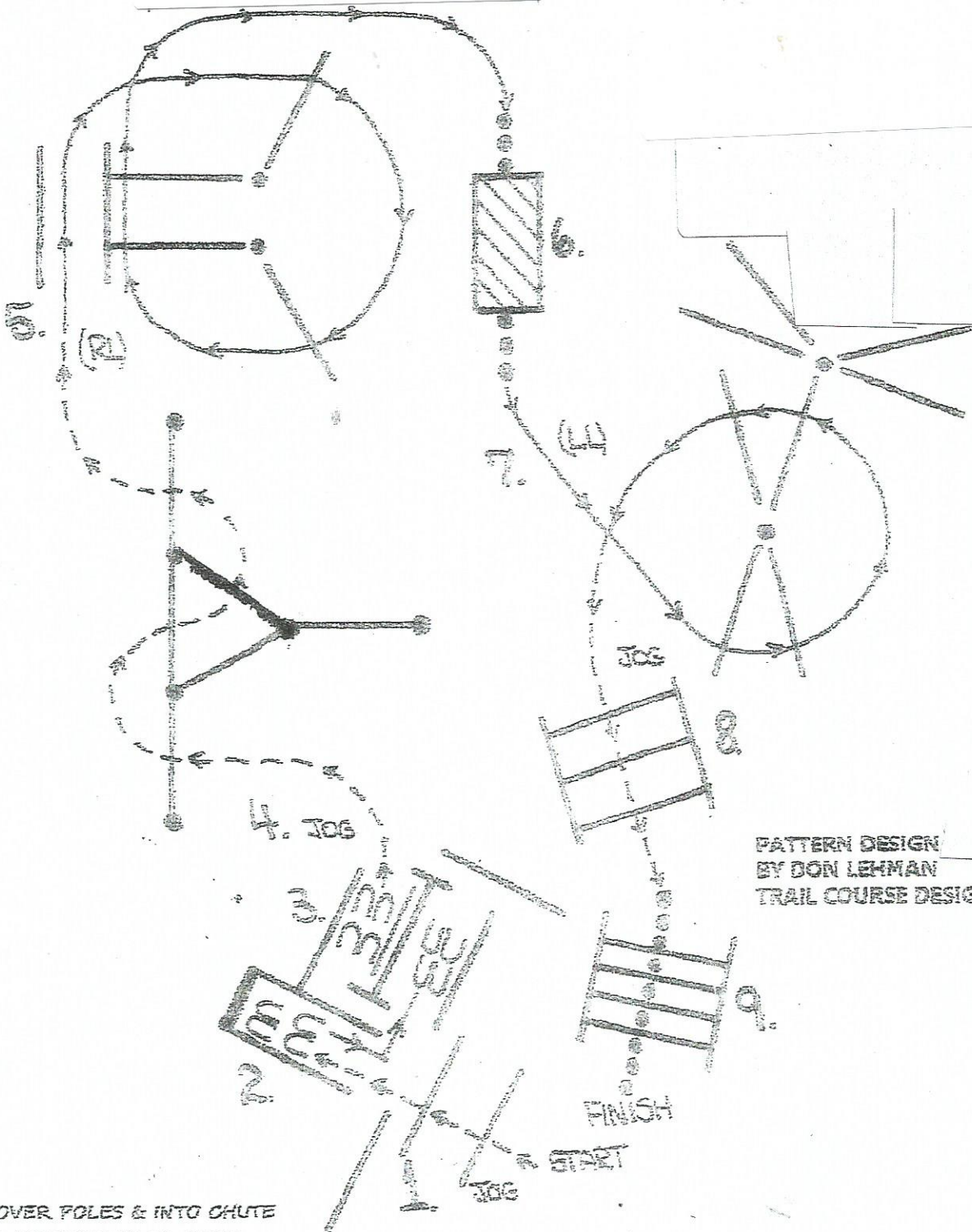

PATTERN DESIGN
BY DON LEHMAN
TRAIL COURSE DESIGNER

1. JOG OVER POLES & INTO CHUTE
2. BACK THRU POLES TO GATE
3. GATE (RH) RIDE THRU OVER POLE CLOSE
4. JOG THRU SERPENTINE & OVER POLES
5. LOPE OVER 4 POLES (RL) TO BRIDGE & STOP
6. WALK OVER BRIDGE
7. LOPE OVER 4 POLES (LL)
8. JOG OVER POLES
9. WALK OVER POLES